

## Stressing Anchorage VSL Type SA

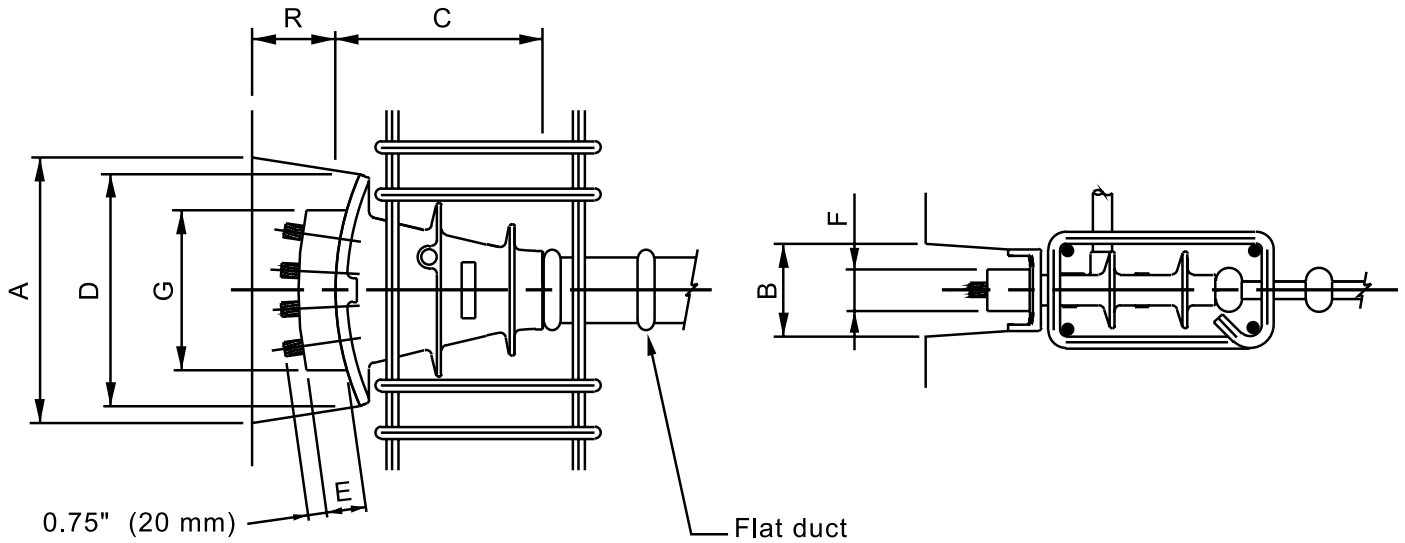

Type	A	B	C	D	E	F	G	R
SA5-4	10.42	3.70	8.50	9.75	1.75	1.96	6.75	4.33
SA5-5	10.42	3.70	8.50	9.75	1.75	1.96	8.25	4.33
SA6-4	10.42	3.70	8.50	9.75	2.24	2.64	7.51	4.33

Other sizes available on request

Subject to modification

For proper design and detailing of anchorage zones and related reinforcement, refer to the VSL Publication "Detailing for Post-Tensioning".

Dimensions in inches.

Dimensions are valid for:

- Nominal concrete cylinder strength at 28 days: 4,000 psi (28 MPa).

- Maximum prestressing force may be applied when concrete reaches a cylinder strength of 80% of its nominal strength or 3,000 psi (20 MPa) whichever is less.
- Temporary overstressing to 80% of Guaranteed Ultimate Tensile Strength.
- Information for other concrete strengths and conditions are available from your local VSL Representative.